

*Free Toho*  
1997

# Fundamentals of UV-visible spectroscopy

*A Primer*

Tony Owen

## Preface

In 1988 we published a primer entitled "The Diode-Array Advantage in UV/Visible Spectroscopy". At the time, although diode array spectrophotometers had been on the market since 1979, their characteristics and their advantages compared with conventional scanning spectrophotometers were not well-understood. We sought to rectify the situation. The primer was very well-received, and many thousands of copies have been distributed.

Much has changed in the years since the first primer, and we felt this was an appropriate time to produce a new primer. Computers are used increasingly to evaluate data; Good Laboratory Practice has grown in importance; and a new generation of diode array spectrophotometers is characterized by much improved performance. With this primer, our objective is to review all aspects of UV-visible spectroscopy that play a role in obtaining the best results. Microprocessor and/or computer control has taken much of the drudgery out of data processing and has improved productivity. As instrument manufacturers, we would like to believe that analytical instruments are now easier to operate. Despite these advances, a good knowledge of the basics of UV-visible spectroscopy, of the instrumental limitations, and of the pitfalls of sample handling and sample chemistry remains essential for good results.

With this primer, we also want to show that the conventional "single measurement at a single wavelength" approach to obtaining results is insufficient for assuring optimum results. Multiple measurements at multiple wavelengths or (preferably) full spectra yield the best accuracy and precision of results and provide the information necessary to detect erroneous results.

I would like to take this opportunity to thank my colleagues, too numerous to mention by name, at Hewlett-Packard from whom I have learned so much about UV-visible spectroscopy over the years.

© Copyright Hewlett-Packard Company, 1996. All rights reserved. Reproduction, adaptation, or translation without prior written permission is prohibited, except as allowed under the copyright laws.

The information contained in this primer is subject to change without notice.

Printed in Germany 09/96

Hewlett-Packard publication number  
12-5965-5123E

Detectors .....	41
Optics .....	43
The conventional spectrophotometer .....	44
The diode array spectrophotometer .....	45
Configuration .....	47
Single-beam design .....	47
Dual-beam design .....	48
Split-beam design .....	50
Dual-wavelength design .....	51
Measuring a spectrum .....	51
Key instrumental parameters .....	52
Spectral resolution .....	52
Wavelength accuracy and precision .....	55
Photometric accuracy and precision .....	57
Stray light .....	57
Noise .....	58
Linear dynamic range .....	59
Drift .....	61

### Chapter 3 Sample handling and measurement

Liquid samples .....	64
Cells .....	64
Material .....	64
Cell types .....	65
Sources of error .....	66
Care of cells .....	67
Choice of solvent .....	67
Effect of solvent, concentration, pH, and temperature .....	68
Solid samples .....	70
No reference .....	70
Refractive index .....	71
Sample geometry .....	71
Weak absorbance .....	72
Changing slit width .....	72
Time averaging .....	73
Wavelength averaging .....	73
Strong absorbance .....	74
Interference .....	75
Types of interference .....	75
Other absorbing compounds .....	76
Scattering .....	76
Correction techniques .....	77
Isoabsorbance .....	78
Multicomponent analysis .....	78

Background modeling .....	79
Internal referencing .....	80
Three-point correction .....	80
Derivative spectroscopy .....	81
Photochemical problems .....	85
Fluorescence .....	85
Sample decomposition .....	86

### Chapter 4 Method development and validation

Method development .....	88
Linearity .....	89
Accuracy .....	93
Precision .....	94
Sensitivity .....	95
Range .....	97
Selectivity .....	97
Ruggedness .....	99
Instrumental requirements .....	100
Method validation .....	100

### Chapter 5 Routine operation

Instrument performance verification .....	102
Test parameters .....	102
Wavelength accuracy and precision .....	103
Photometric accuracy and precision .....	104
Stray light .....	104
Resolution .....	105
Noise .....	105
Baseline flatness .....	106
Stability .....	106
Linearity .....	106
Standards .....	107
Emission standards .....	107
Solid absorption standards .....	107
Liquid absorption standards .....	108
Regulatory requirements .....	110
GLP/GMP .....	110
European Pharmacopoeia .....	110
United States Pharmacopoeia .....	111
American Standard Testing Methods .....	113
Recommendations .....	115
Instrument self-test .....	119

## Contents

### Chapter 1 Principles and applications of UV-visible spectroscopy

Basic principles .....	10
The electromagnetic spectrum.....	10
Wavelength and frequency.....	11
Origin of UV-visible spectra .....	11
Transmittance and absorbance .....	14
Derivative spectra .....	14
Obtaining derivative spectra .....	16
Applications .....	17
Signal-to-noise.....	17
Instrumental considerations .....	18
Qualitative analysis .....	18
Identification—spectra and structure .....	18
Confirmation of identity.....	19
Color .....	21
Other qualitative information .....	22
Protein and nucleic acid melting temperature .....	22
Enzyme activity.....	23
Instrumental considerations.....	24
Quantitative analysis .....	24
Beer's law .....	24
Sample requirements .....	28
Multicomponent analysis .....	29
Principle of additivity.....	29
Simple simultaneous equations method .....	29
Least squares method .....	32
Other methods .....	34
Sample requirements .....	34
Instrumental requirements .....	34
Indirect quantification .....	35
Chemical derivatization.....	35
Spectrophotometric titrations.....	35
Enzyme kinetic assays.....	36

### Chapter 2 Instrumentation

Instrumental design.....	38
Components .....	38
Sources .....	39
Dispersion devices .....	40

This chapter outlines the basic theories and principles of UV-visible spectroscopy. These provide valuable insight into the uses and limitations of this technique for chemical analysis. The primary applications of UV-visible spectroscopy are also briefly reviewed.

## Basic principles

### The electromagnetic spectrum

Ultraviolet (UV) and visible radiation comprise only a small part of the electromagnetic spectrum, which includes such other forms of radiation as radio, infrared (IR), cosmic, and X rays (see Figure 1).

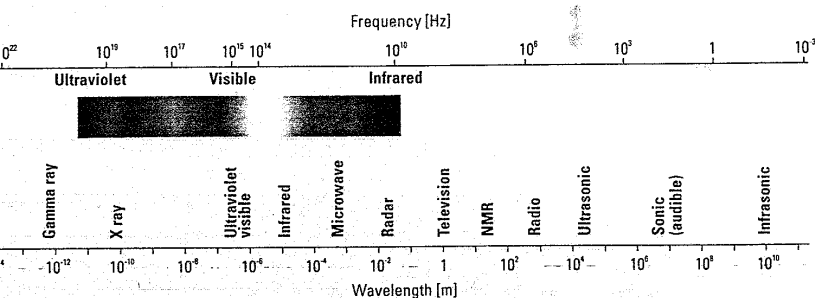

Figure 1  
The electromagnetic spectrum

The energy associated with electromagnetic radiation is defined by the following equation:

$$E = h\nu$$

where  $E$  is energy (in joules),  $h$  is Planck's constant ( $6.62 \times 10^{-34}$  Js), and  $\nu$  is frequency (in seconds).

### Wavelength and frequency

Electromagnetic radiation can be considered a combination of alternating electric and magnetic fields that travel through space with a wave motion. Because radiation acts as a wave, it can be classified in terms of either wavelength or frequency, which are related by the following equation:

$$\nu = c/\lambda$$

where  $\nu$  is frequency (in seconds),  $c$  is the speed of light ( $3 \times 10^8$  ms<sup>-1</sup>), and  $\lambda$  is wavelength (in meters). In UV-visible spectroscopy, wavelength usually is expressed in nanometers (1 nm =  $10^{-9}$  m).

It follows from the above equations that radiation with shorter wavelength has higher energy. In UV-visible spectroscopy, the low-wavelength UV light has the highest energy. In some cases, this energy is sufficient to cause unwanted photochemical reactions when measuring sample spectra (remember, it is the UV component of light that causes sunburn).

### Origin of UV-visible spectra

When radiation interacts with matter, a number of processes can occur, including reflection, scattering, absorbance, fluorescence/phosphorescence (absorption and reemission), and photochemical reaction (absorbance and bond breaking). In general, when measuring UV-visible spectra, we want only absorbance to occur.

Because light is a form of energy, absorption of light by matter causes the energy content of the molecules (or atoms) to increase. The total potential energy of a molecule

Contents

System suitability .....	120
Proper operation .....	120
Electronic storage .....	121
Standard operating procedures .....	121
Collateral data .....	121
Confirmation wavelengths .....	122
Full spectra .....	122
Statistics .....	124

**Appendix A Accuracy and precision**

Definition of terms .....	126
---------------------------	-----

**Appendix B Characteristics of diode array spectrophotometers**

Advantages of diode array spectroscopy .....	128
Fast spectral acquisition .....	128
Simultaneous multiwavelength measurement .....	129
Wavelength resettability .....	130
Sensitivity .....	131
Measurement statistics .....	131
Ruggedness and reliability .....	131
Open sample area .....	132
Disadvantages of diode array spectroscopy .....	132
Resolution .....	132
Stray light .....	133
Sample decomposition .....	133
Complexity .....	134
Errors in measuring fluorescent samples .....	134

References .....	135
------------------	-----

Index .....	139
-------------	-----

---

*chapter 1*

Principles and applications of UV-visible spectroscopy

generally is represented as the sum of its electronic, vibrational, and rotational energies:

$$E_{\text{total}} = E_{\text{electronic}} + E_{\text{vibrational}} + E_{\text{rotational}}$$

The amount of energy a molecule possesses in each form is not a continuum but a series of discrete levels or states. The differences in energy among the different states are in the order:

$$E_{\text{electronic}} > E_{\text{vibrational}} > E_{\text{rotational}}$$

In some molecules and atoms, photons of UV and visible light have enough energy to cause transitions between the different electronic energy levels. The wavelength of light absorbed is that having the energy required to move an electron from a lower energy level to a higher energy level. Figure 2 shows an example of electronic transitions in formaldehyde and the wavelengths of light that cause them.

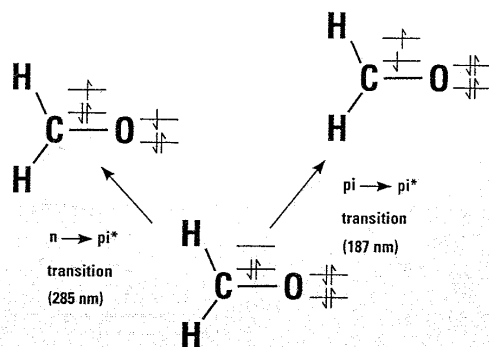

Figure 2  
Electronic transitions in formaldehyde

These transitions should result in very narrow absorbance bands at wavelengths highly characteristic of the difference in energy levels of the absorbing species. This is true for atoms, as depicted in Figure 3.

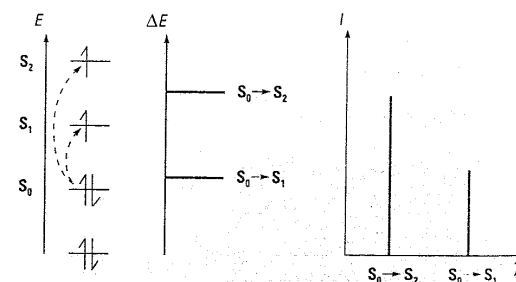

Figure 3  
Electronic transitions and spectra of atoms

However, for molecules, vibrational and rotational energy levels are superimposed on the electronic energy levels. Because many transitions with different energies can occur, the bands are broadened (see Figure 4). The broadening is even greater in solutions owing to solvent-solute interactions.

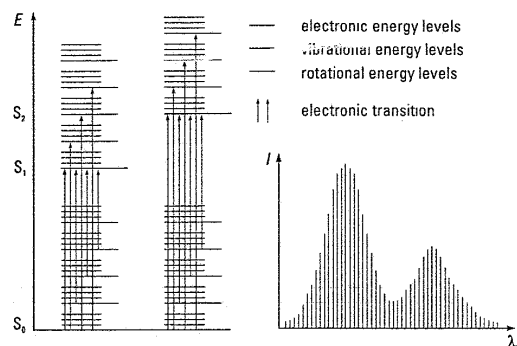

Figure 4  
Electronic transitions and UV-visible spectra in molecules

### Transmittance and absorbance

When light passes through or is reflected from a sample, the amount of light absorbed is the difference between the incident radiation ( $I_0$ ) and the transmitted radiation ( $I$ ). The amount of light absorbed is expressed as either transmittance or absorbance. Transmittance usually is given in terms of a fraction of 1 or as a percentage and is defined as follows:

$$T = I/I_0 \text{ or } \%T = (I/I_0) \times 100$$

Absorbance is defined as follows:

$$A = -\log T$$

For most applications, absorbance values are used since the relationship between absorbance and both concentration and path length normally is linear.

### Derivative spectra

If a spectrum is expressed as absorbance ( $A$ ) as a function of wavelength ( $\lambda$ ), the derivative spectra are:

Zero order:  $A = f(\lambda)$

First order:  $\frac{dA}{d\lambda} = f'(\lambda)$

Second order:  $\frac{d^2A}{d\lambda^2} = f''(\lambda)$

Figure 5 on the next page shows the effects of derivatization on a simple Gaussian absorbance band. The derivative spectra are always more complex than the zero-order spectrum.

The first derivative is the rate of change of absorbance against wavelength. It starts and finishes at zero, passing through zero at the same wavelength as  $\lambda_{\max}$  of the absorbance band. This derivative has a positive and a negative band with maximum and minimum at the same wavelengths as the inflection points in the absorbance band. This bipolar function is characteristic of all odd-order derivatives.

The most distinctive feature of the second-order derivative is a negative band with minimum at the same wavelength as the maximum on the zero-order band. This derivative also shows two positive satellite bands on either side of the main band. The fourth derivative shows a positive band with a maximum at the same wavelength as the maximum on the zero order band. Even-order derivatives show a negative or positive band with minimum or maximum at the same wavelength as  $\lambda_{\max}$  on the absorbance band.



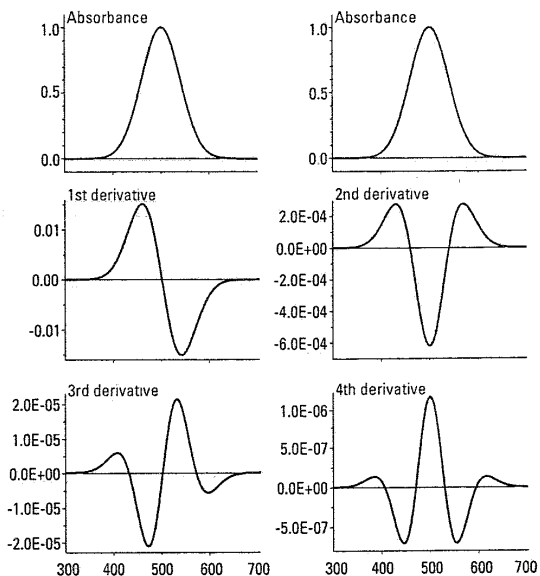

Figure 5  
Derivative spectra of a Gaussian absorbance band

**Obtaining derivative spectra** Optical, electronic, and mathematical methods all can be used to generate derivative spectra. Although optical and electronic techniques formed the basis of early UV-visible spectroscopy, these have been largely superseded by mathematical methods.

To calculate the derivative at a particular wavelength ( $\lambda$ ), a window of  $\pm n$  data points is selected, and a polynomial

$$A_{\lambda} = a_0 + a_1\lambda + \dots + a_l\lambda^l$$

is fitted by the least squares method. The coefficients  $a_0 \dots a_l$  at each wavelength are the derivative values, where  $a_1$  is the first derivative,  $a_2$  is the second derivative, and so on. Savitzky and Golay<sup>1</sup> developed a highly efficient method to perform the calculations that is the basis of the derivatization algorithm in most commercial instruments. This method also smooths the data. If the polynomial order ( $l$ ) is less than the number of data points ( $2n+1$ ) in the window, the polynomial generally cannot pass through all data points. Thus the least squares fit gives a smoothed approximation to the original data points.

Although transforming a UV-visible spectrum to its first or a higher derivative usually yields a more complex profile than the zero-order spectrum (see Figure 5), the intrinsic information content is not increased. In fact, it is decreased by the loss of lower-order data such as constant offset factors.

**Applications** Derivative spectra can be used to enhance differences among spectra, to resolve overlapping bands in qualitative analysis (see "Confirmation of identity" on page 19) and, most importantly, to reduce the effects of interference from scattering, matrix, or other absorbing compounds in quantitative analysis (see "Derivative spectroscopy" on page 81).

**Signal-to-noise** An unwanted effect of the derivatization process is the decrease in S/N with higher orders of derivatives. This decrease follows from the discrimination effect (see "Derivative spectroscopy" on page 81) and from the fact that noise always contains the sharpest features in the spectrum. Thus, if the spectral data used in the derivative calculation are at 2-nm intervals, the noise has a 2-nm bandwidth. If the analyte band has a bandwidth of 20 nm, the S/N of the first derivative will be 10 times worse than with the zero-order spectrum. The smoothing properties of the Savitzky-Golay polynomial technique can be used to mitigate the decrease in S/N, but care must be taken as too

high a degree of smoothing will distort the derivative spectrum.

#### Experimental considerations

The higher resolution of derivative spectra places increased demands on the wavelength reproducibility of the spectrophotometer. Small wavelength errors can result in much larger signal errors in the derivative mode than in the absorbance mode.

The negative effect of derivatization on S/N also places increased demands on low-noise characteristics of the spectrophotometer. If the spectrophotometer can scan and average multiple spectra, S/N can be improved further prior to derivatization.

#### Qualitative analysis

#### Identification—spectra and structure

UV-visible spectra generally show only a few broad absorbance bands. Compared with techniques such as infrared spectroscopy, which produces many narrow bands, UV-visible spectroscopy provides a limited amount of qualitative information. Most absorption by organic compounds results from the presence of  $\pi$  (that is, unsaturated) bonds. A chromophore is a molecular group usually containing a  $\pi$  bond. When inserted into a saturated hydrocarbon (which exhibits no UV-visible absorbance spectrum), it produces a compound with absorption between 185 and 1000 nm. Table 1 lists some chromophores and the wavelengths of their absorbance maxima.

Table 1 Selected chromophores and their absorbance maxima

Chromophore	Formula	Example	$\lambda_{\text{max}}$ (nm)
Carbonyl (ketone)	RR'C=O	Acetone	271
Carbonyl (aldehyde)	RHC=O	Acetaldehyde	293

Table 1 Selected chromophores and their absorbance maxima

Carboxyl	RCOOH	Acetic acid	204
Amide	RCONH <sub>2</sub>	Acetamide	208
Ethylene	RCH=CHR	Ethylene	193
Acetylene	RC=CR	Acetylene	173
Nitrile	RC=N	Acetonitrile	< 160
Nitro	RNO <sub>2</sub>	Nitromethane	271

The presence of an absorbance band at a particular wavelength often is a good indicator of the presence of a chromophore. However, the position of the absorbance maximum is not fixed but depends partially on the molecular environment of the chromophore and on the solvent in which the sample may be dissolved. Other parameters, such as pH and temperature, also may cause changes in both the intensity and the wavelength of the absorbance maxima.

Conjugating the double bond with additional double bonds increases both the intensity and the wavelength of the absorption band. For some molecular systems, such as conjugated hydrocarbons or carotenoids, the relationship between intensity and wavelength has been systematically investigated.

Transition metal ions also have electronic energy levels that cause absorption of 400–700 nm in the visible region.

#### Confirmation of identity

Although UV-visible spectra do not enable absolute identification of an unknown, they frequently are used to confirm the identity of a substance through comparison of the measured spectrum with a reference spectrum.

Where spectra are highly similar, derivative spectra may be used. As shown in Figure 6, the number of bands increases with higher orders of derivatives. This increase in

complexity of the derivative spectra can be useful in qualitative analysis, either for characterizing materials or for identification purposes. For example, the absorbance spectrum of the steroid testosterone shows a single, broad, featureless band centered at around 330 nm, whereas the second derivative shows six distinct peaks.

The resolution enhancement effect may be of use as well in identifying an unknown. Figure 6 shows a computer simulation. When two Gaussian bands with a 40-nm natural spectral bandwidth (NBW) separated by 30 nm are added in absorbance mode, a single band with a maximum midway between the two component bands results. The two components are not resolved. In the fourth derivative, these two bands are clearly visible, with maxima centered close to the  $\lambda_{\text{max}}$  of the component bands.

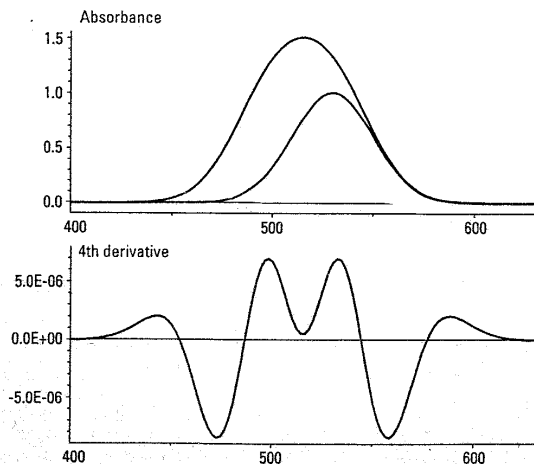

Figure 6  
Resolution enhancement

**Color** Color is an important property of a substance. The color of matter is related to its absorptivity or reflectivity. The human eye sees the complementary color to that which is absorbed, as shown in Figure 7 and Figure 8.

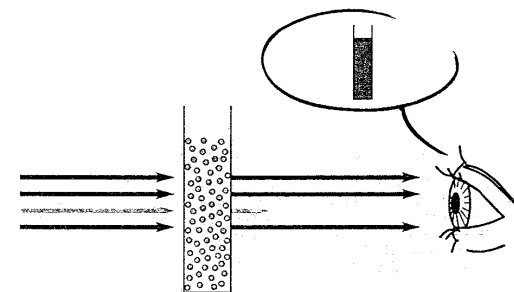

Figure 7  
Transmission and color

Wavelength [nm]	Absorbed color	Complementary color
650-780	red	blue-green
595-650	orange	greenish blue
560-595	yellow-green	purple
500-560	green	red-purple
490-500	bluish green	red
480-490	greenish blue	orange
435-480	blue	yellow
380-435	violet	yellow-green

Figure 8  
Absorbance and complementary colors

In practice, both the generation and sensation of color are highly complex and depend on many factors, including the spectrum of the illuminant and, in the case of solids, the surface structure. Specialized color measurement systems, such as the CIE  $L^*a^*b$ , and instrumentation to measure color have been developed. When equipped with the appropriate software, most spectrophotometers can be used to measure color. An in-depth discussion of color is beyond the scope of this primer. Several well-written publications<sup>2,3</sup> discuss color and the measurement of color in detail.

#### Other qualitative information

UV-visible spectroscopy can be used to determine many physicochemical characteristics of compounds and thus can provide information as to the identity of a particular compound. Two examples follow.

#### Protein and nucleic acid melting temperature

The absorbance spectra of proteins result largely from the presence of the aromatic amino acids tryptophan, tyrosine, and phenylalanine. A protein at room temperature has a specific tertiary structure or conformation that in turn creates a specific electronic environment for the aromatic amino acids. If the protein is heated it will, at a certain temperature, unfold or melt and lose its structure. In this process, the electronic environment of the aromatic amino acids changes, which in turn results in spectral changes or shifts.

Multicomponent analysis (see "Multicomponent analysis" on page 29) can be used to determine how many of each aromatic amino acid are present in an intact protein.<sup>4</sup>

Deoxyribonucleic acid (DNA) in its native state comprises two strands of deoxyribose molecules helically wound around the same axis. The strands are linked by hydrogen bonds between the purine and pyrimidine bases—adenine is joined to thymine (A-T), and guanine to cytosine (G-C). These bases are primarily responsible for the UV absorbance of DNA, with a peak maximum at 260 nm. As in

any multicomponent system, the observed absorption of any DNA molecule should equal the sum of the individual absorbances:

$$A_{\text{DNA}} = A_{\text{adenine}} + A_{\text{guanine}} + A_{\text{cytosine}} + A_{\text{thymine}}$$

However, the observed absorbance is always significantly less than expected because the hydrogen bonding between the bases changes their electronic environment. When a molecule is heated, the hydrogen bonds break, the double helix unwinds, and the absorbance increases so that it approaches that expected from the sum of all bases. This denaturation process also is known as melting. In a DNA melt experiment, the temperature of a DNA solution is increased in a stepwise fashion, and the absorbance at 260 nm at each temperature is measured and plotted as a melting curve.

The midpoint of the temperature range over which the melting occurs is the  $T_m$  value. The  $T_m$  value of a particular DNA sample depends primarily on the percentage of G-C pairs in the sample, each of which contains three hydrogen bonds (in contrast, each A-T pair contains two hydrogen bonds). The higher the percentage of G-C pairs in the sample, the higher the observed  $T_m$ .

#### Enzyme activity

The activity of an enzyme is a measure of its effectiveness as a catalyst. The concentration of enzyme in an impure preparation can be expressed in terms of units per milliliter, and the specific activity of the preparation can be expressed as units per milligram of protein. As an enzyme is purified, the specific activity increases to a limit (that of the pure enzyme).

Because reaction rate varies with such factors as substrate concentration, pH, ionic strength, and temperature, the conditions under which the activity is determined must be defined precisely. These conditions are usually the optimal assay conditions at a fixed temperature (25, 30, or 37 °C),

with all substrates present at saturating conditions. To determine activity, a system is set up with known concentrations of substrate and, if necessary, coenzyme. A known weight of the enzyme is added and the rate of reaction determined. Activity measurements are conducted primarily in the research environment as enzymes are isolated and purified, and in the manufacture of enzyme assay kits, in which the enzyme activity must be consistent from batch to batch.

### Instrumental considerations

Absolute wavelength accuracy and absolute photometric accuracy are very important in qualitative analysis, particularly for the identification and confirmation of unknowns. Often spectra acquired on different instruments at different times are compared. In this regard, spectra may have to be measured at a defined instrumental resolution.

### Quantitative analysis

**Beer's law** If 100 photons of light enter a cell and only 50 emerge from the other side, the transmittance is 0.5, or 50%. If these 50 photons then pass through an identical cell, only 25 will emerge, and so forth. Figure 9 shows the plot of transmittance against concentration.

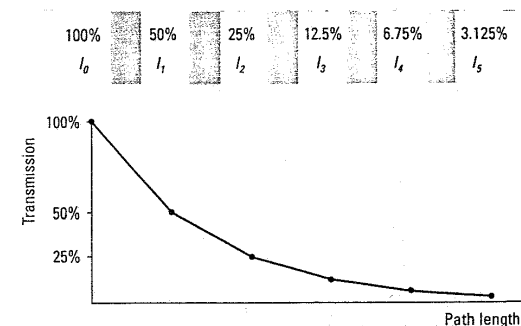

Figure 9  
Transmittance and concentration—the Bouguer-Lambert law

Lambert (1760) generally is credited with the first mathematical formulation of this effect, although it now appears that Bouguer first stated it in 1729. The mathematical expression is:

$$T = I/I_0 = e^{-kb}$$

where  $I_0$  is the incident intensity,  $I$  is the transmitted intensity,  $e$  is the base of natural logarithms,  $k$  is a constant, and  $b$  is the path length (usually in centimeters).

Beer's law is identical to Bouguer's law, except that it is stated in terms of concentration. The amount of light absorbed is proportional to the number of absorbing molecules through which the light passes. Figure 10 shows a plot of transmittance against path length.

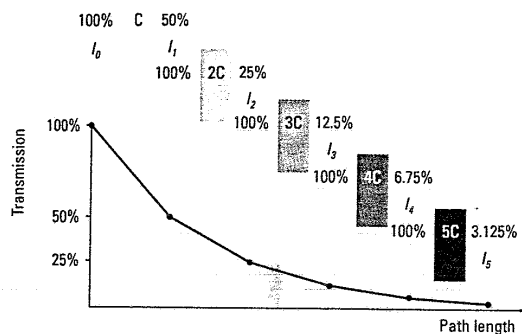

Figure 10  
Transmittance and path length—Beer's law

Combining the two laws gives the Beer–Bouguer–Lambert law:

$$T = I/I_0 = e^{-kbc}$$

where  $c$  is the concentration of the absorbing species (usually expressed in grams per liter or milligrams per liter). This equation can be transformed into a linear expression by taking the logarithm and is usually expressed in the decadic form:

$$A = -\log T = -\log(I/I_0) = \log(I_0/I) = \epsilon bc$$

where  $\epsilon$  is the molar absorption or extinction coefficient. This expression is commonly known as Beer's law. Figure 11 shows a plot of absorbance against concentration.

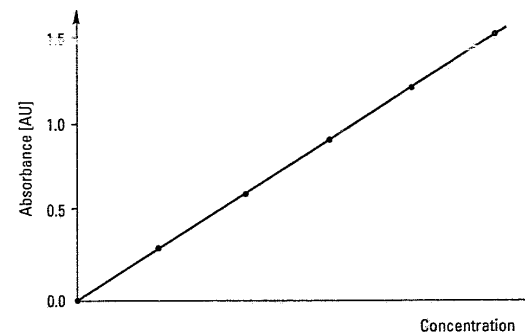

Figure 11  
The Beer–Bouguer–Lambert law

The extinction coefficient ( $\epsilon$ ) is characteristic of a given substance under a precisely defined set of conditions, such as wavelength, solvent, and temperature. In practice, the measured extinction coefficient also depends partially on the characteristics of the instrument used. For these reasons, predetermined values for the extinction coefficient usually are not used for quantitative analysis. Instead, a calibration or working curve for the substance to be analyzed is constructed using one or more standard solutions with known concentrations of the analyte.

For electronic transitions, the difference in energy between ground and excited states is relatively large. Therefore, at room temperature, it is highly likely that all molecules are in the electronic ground state. Absorption and return to ground state are fast processes, and equilibrium is reached very quickly. Thus, absorption of UV-visible light is quantitatively highly accurate. The simple linear relationship between absorbance and concentration and the relative ease of measurement of UV-visible light have made

UV-visible spectroscopy the basis for thousands of quantitative analytical methods.

Assuming Beer's law is obeyed for the zero-order spectrum, a similar linear relationship exists between concentration and amplitude for all orders of derivative spectra:

$$\text{Zero order:} \quad A = \epsilon bc$$

$$\text{First derivative:} \quad \frac{dA}{d\lambda} = \frac{d\epsilon}{d\lambda} bc$$

$$n^{\text{th}} \text{ derivative:} \quad \frac{d^n A}{d\lambda^n} = \frac{d^n \epsilon}{d\lambda^n} bc$$

at  $\lambda$ , where  $A$  is absorbance,  $\epsilon$  is the extinction coefficient,  $b$  is the sample path length, and  $c$  is the sample concentration.

For single-component quantification, the selection of wavelengths is more difficult with derivative spectra than with absorbance spectra since both positive and negative peaks are present. The even-order derivatives have a peak maximum or minimum at the same  $\lambda_{\text{max}}$  as the absorbance spectrum, but for the odd-order derivatives, this wavelength is a zero-crossing point. Taking the difference between the highest maximum and the lowest minimum gives the best S/N but may result in increased sensitivity to interference from other components.

#### Sample requirements

For accurate results, the sample to be analyzed must contain only the absorbing component for which the calibration has been performed. If the sample is a solution, a pure sample of the solvent should be used as a blank. It may be possible to correct for an interfering component with a second wavelength.

### Multicomponent analysis

Multicomponent analyses using UV-visible spectra have been performed for almost as long as single-component analyses, but because the techniques used in multicomponent analysis often gave incorrect results (as detailed below), they were not widely applied. However, modern instruments yield more precise data, and modern curve-fitting techniques give more accurate results and—perhaps more importantly—indicate when results are incorrect. For these reasons, multicomponent UV-visible analyses are becoming more popular.

#### Principle of additivity

According to Beer's law (see "Beer's law" on page 24), absorbance is proportional to the number of molecules that absorb radiation at the specified wavelength. This principle is true if more than one absorbing species is present. All multicomponent quantitative methods are based on the principle that the absorbance at any wavelength of a mixture is equal to the sum of the absorbance of each component in the mixture at that wavelength.

#### Simple simultaneous equations method

The simple approach to multicomponent analysis is based on measurements at a number of wavelengths equal to the number of components in the mixture. The wavelengths chosen usually are those of the absorbance maximum of each component. For calibration, the absorbance of standards of known concentrations of pure components is measured to determine the extinction coefficient for each component at each wavelength selected.

The absorbance of the mixture at each wavelength is the sum of the absorbance of each component at that wavelength, which in turn depends on the extinction coefficient and the concentration of each component. Thus for two components  $x$  and  $y$ , the equations are:

$$A'_{(x+y)} = A'_x + A'_y = e'_x bc_x + e'_y bc_y$$

and

$$A''_{(x+y)} = A''_x + A''_y = e''_x b c_x + e''_y b c_y$$

where  $A'$  is absorbance at wavelength ' $\lambda$ ',  $A''$  is absorbance at wavelength ' $\lambda''$ ',  $e'$  is molar absorptivity at wavelength ' $\lambda$ ',  $e''$  is molar absorptivity at wavelength ' $\lambda''$ ',  $c$  is concentration, and  $b$  is path length.

These equations are easily solved to determine the concentration of each component. If measurements were always perfect, accurate results could be obtained even for complex mixtures of components with very similar spectra. In practice, however, measurement errors always occur. Such errors can affect significantly the accuracy of results when spectra overlap significantly. Figure 12 shows a simulated two-component mixture with no overlap of the spectra at the absorbance maxima.

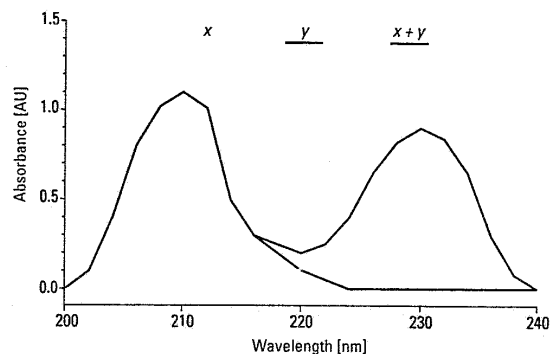

Figure 12  
A two-component mixture with little spectral overlap

In contrast, Figure 13 shows a simulated two-component mixture with significant overlap of the spectra at the absorbance maxima.

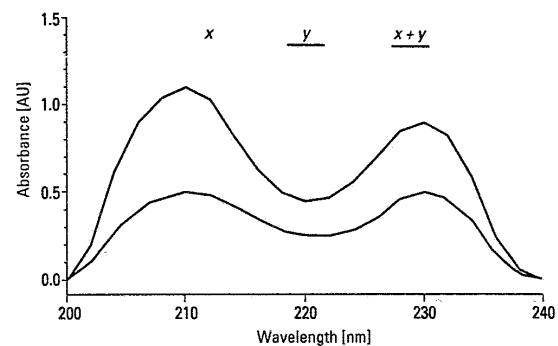

Figure 13  
A two-component mixture with significant spectral overlap

For a mixture of  $x$  and  $y$  where  $cx = cy = 1$ , the measured absorbances should be:

With little spectral overlap	With substantial spectral overlap
$A_{(x+y)} = 1.1 + 0.0 = 1.1$	$A_{(x+y)} = 0.6 + 0.5 = 1.1$
$A'_{(x+y)} = 0.0 + 0.9 = 0.9$	$A'_{(x+y)} = 0.4 + 0.5 = 0.9$

If a 10% error occurs in the measurement of  $A'_{(x+y)}$  and  $A''_{(x+y)}$ , that is,  $A'_{(x+y)} = 0.99$  (-10%) and  $A''_{(x+y)} = 0.99$  (+10%), the quantitative calculation yields the results shown in Table 2:



Table 2 Comparison of multicomponent analysis results for examples with little and substantial spectral overlap

Component	Nominal concentration	Little spectral overlap		Substantial spectral overlap	
		Calculated concentration	% error	Calculated concentration	% error
x	1	0.9	-10 %	0	-100 %
y	1	1.1	+10 %	1.98	+98 %

**Least squares method** The effect of random noise can be reduced through the use of additional spectral information, that is, a series of data points can be used for quantification instead of only two. In this so-called overdetermined system, a least squares fit of the standard spectra to the spectrum of the measured sample yields quantitative results.<sup>5,6</sup> Figure 14 depicts a spectrum for the two-component mixture shown in Figure 13 with a 10 % random error at each measurement point.

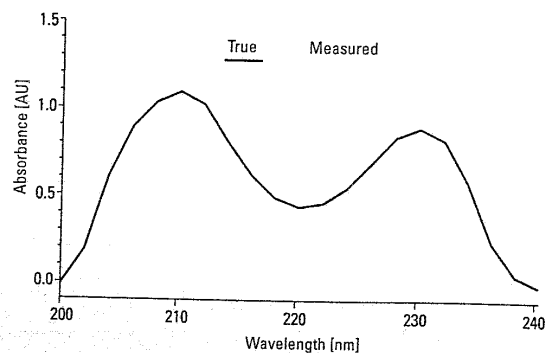

Figure 14 Mixture spectrum with 10 % random error at each wavelength

With 21 data points (2-nm intervals over 200–240 nm), the quantitative results from the least squares method have an error of < 1 % compared with an error of approximately 100 % from the usual measurements at two wavelengths, as shown in Table 3.

Table 3 Comparison of multicomponent analysis results from simple simultaneous equations and least squares methods

Component	Nominal concentration	Using 210 and 230 nm only		Using 200–240 nm	
		Calculated concentration	% error	Calculated concentration	% error
x	1	0.0	-10 %	1.003	+0.3 %
y	1	1.98	+10 %	0.995	-0.5 %

This method enables the analysis of more complex mixtures and of simple mixtures of components with similar spectra.

The residual from the least squares calculation is a good indicator of how well the standard spectra fit the sample spectra and is therefore a good indicator of the probable accuracy of the results.

An example of multicomponent analysis is the quantification of five hemoglobins in blood with minimum sample preparation.<sup>7</sup> Figure 15 shows the absorption spectra of hemoglobin derivatives. This analysis was previously performed using various analytical techniques, including spectroscopy and titrations.

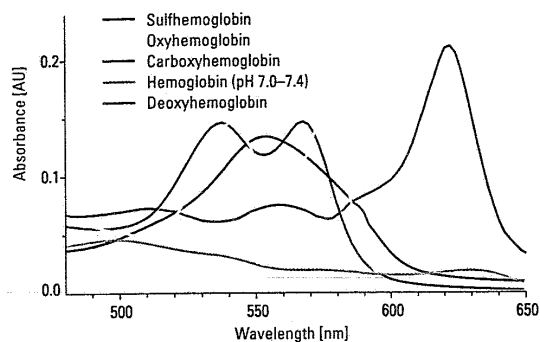

Figure 15  
Absorption spectra of hemoglobin derivatives

**Other methods** Other statistical approaches to multicomponent analysis include the partial least squares (PLS), principle component regression (PCR), and multiple least squares (MLS) methods. In theory, these methods offer some advantages over those described above, but in practice the calibration process is much more complex.

**Sample requirements** The simple simultaneous equations and least squares methods yield accurate results only if calibration is performed using pure standards or mixtures of standards for each component in the sample that contributes to the UV spectrum. The unknown sample must not have any additional absorbing capacity.

**Instrumental requirements** Single-component quantification is normally performed by measuring with the same instrument a standard or series of standards followed by an unknown. This calibration process should eliminate instrumental bias, making absolute wavelength accuracy and absolute photometric accuracy relatively unimportant. On the other hand,

photometric reproducibility is essential for precise results. If measurements are performed only at the absorbance maximum, wavelength reproducibility is also of little importance because the rate of change of absorbance with wavelength is low. However, if a wavelength on the side of the band is used, wavelength reproducibility becomes very important. Finally, the instrumental linear range is critical, as the calibration process relies on a linear relationship.

Accurate multicomponent analyses require excellent S/N, especially if the simple simultaneous equations method is used. In the least squares method, data from the sides of absorbance bands is incorporated into the calculation, making excellent wavelength reproducibility essential as well. Moreover, because more data is required, fast scanning is necessary for productivity.

## Indirect quantification

**Chemical derivatization** Because many compounds exhibit either very weak or no absorbance in the UV or visible regions, a number of methods using chemical derivatization have been developed. Such methods usually involve adding an organic reagent, which forms a complex with strong absorptivity. The final stage of measurement closely resembles that of the direct methods. With this technique, the choice of an appropriate reagent can enhance significantly both sensitivity and selectivity.

**Spectrophotometric titrations** In volumetric analyses, the color changes that signify the end point of a titration are most often detected through visual inspection. This process is inherently subjective and can be a source of error. The use of a spectrophotometer for endpoint detection introduces objectivity into the analysis and lends itself to automation.

### Enzyme kinetic assays

Direct UV-visible analysis of one component in biological matrices, for example blood or foodstuffs, is difficult. Interference from other components often makes impossible direct measurement of a specific property, such as absorbance. Separation of the compound of interest may be costly and time-consuming and thus impracticable for routine analysis.

Enzyme assays can be used in the indirect analysis of one compound or a group of compounds in a complex matrix. If the enzyme is carefully selected, any change in the sample following addition of the enzyme will result only from the reaction of the specific compound or compounds. This selectivity is the basis of enzyme assays.

Enzyme assays can be divided broadly into two types: rate assays and end point assays. The rate of an enzyme depends on many factors, including temperature, pH, enzyme activity, enzyme concentration, and substrate concentration. However, if all other parameters are controlled at a constant level, the rate of reaction is directly proportional to the substrate concentration. With end point assays, the conditions are selected so that the conversion of substrate to product is completed within a reasonable period of time (5–20 min). The difference between initial absorbance and final absorbance is directly proportional to the amount of substrate.

## *chapter 2*

## Instrumentation

Ideally, analytical instruments always yield correct measurements of a chemical or physicochemical parameter, but in practice all instruments are subject to error. In this chapter we review the basic components of a spectrophotometer and the various instrument configurations available. Key instrumental parameters and their potential adverse effects on the measured values are also discussed.

## Instrumental design

### Components

A spectrophotometer is an instrument for measuring the transmittance or absorbance of a sample as a function of the wavelength of electromagnetic radiation. The key components of a spectrophotometer are:<sup>8</sup>

- a source that generates a broad band of electromagnetic radiation
- a dispersion device that selects from the broadband radiation of the source a particular wavelength (or, more correctly, a waveband)
- a sample area
- one or more detectors to measure the intensity of radiation

Other optical components, such as lenses or mirrors, relay light through the instrument.

**Sources** The ideal light source would yield a constant intensity over all wavelengths with low noise and long-term stability. Unfortunately, however, such a source does not exist. Two sources are commonly used in UV-visible spectrophotometers.

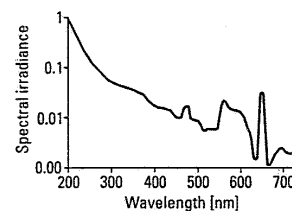

Figure 16  
Intensity spectrum of the  
deuterium arc lamp

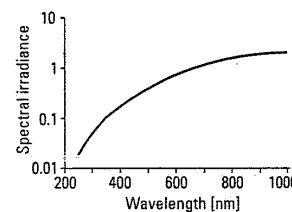

Figure 17  
Intensity spectrum of the  
tungsten-halogen lamp

The first source, the deuterium arc lamp, yields a good intensity continuum in the UV region and provides useful intensity in the visible region (see Figure 16). Although modern deuterium arc lamps have low noise, noise from the lamp is often the limiting factor in overall instrument noise performance. Over time, the intensity of light from a deuterium arc lamp decreases steadily. Such a lamp typically has a half-life (the time required for the intensity to fall to half of its initial value) of approximately 1,000 h.

The second source, the tungsten-halogen lamp (see Figure 17), yields good intensity over part of the UV spectrum and over the entire visible range. This type of lamp has very low noise and low drift and typically has a useful life of 10,000 h.

Most spectrophotometers used to measure the UV-visible range contain both types of lamps. In such instruments, either a source selector is used to switch between the lamps as appropriate, or the light from the two sources is mixed to yield a single broadband source.

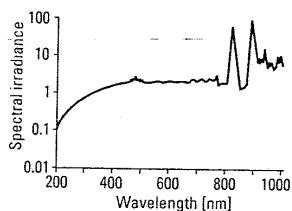

Figure 18  
Intensity spectrum of the  
xenon lamp

An alternate light source is the xenon lamp (see Figure 18), which yields a good continuum over the entire UV and visible regions. However, because the noise from currently available xenon lamps is significantly worse than that from deuterium or tungsten lamps, xenon lamps are used only for applications such as diffuse reflectance measurements, in which high intensity is the primary concern.

### Dispersion devices

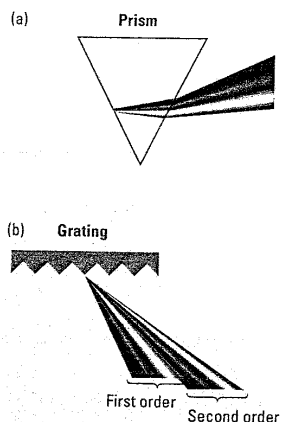

Figure 19  
Dispersion devices

Dispersion devices cause different wavelengths of light to be dispersed at different angles. When combined with an appropriate exit slit, these devices can be used to select a particular wavelength (or, more precisely, a narrow waveband) of light from a continuous source. Two types of dispersion devices, prisms and holographic gratings, are commonly used in UV-visible spectrophotometers.

A prism generates a rainbow from sunlight. This same principle is used in spectrophotometers. Prisms are simple and inexpensive, but the resulting dispersion is angularly nonlinear (see Figure 19a). Moreover, the angle of dispersion is temperature sensitive.

For these reasons, most modern spectrophotometers contain holographic gratings instead of prisms. These devices are made from glass blanks, onto which very narrow grooves are ruled. Traditionally, this task was done mechanically, but modern production methods use a holographic optical process. The dimensions of the grooves are of the same order as the wavelength of light to be dispersed. Finally, an aluminum coating is applied to create a reflecting source. Light falling on the grating is reflected at different angles, depending on the wavelength. Holographic

gratings yield a linear angular dispersion with wavelength and are temperature insensitive. However, they reflect light in different orders, which overlap (see Figure 19b). As a result, filters must be used to ensure that only the light from the desired reflection order reaches the detector. A concave grating disperses and focuses light simultaneously.

A monochromator consists of an entrance slit, a dispersion device, and an exit slit. Ideally, the output from a monochromator is monochromatic light. In practice, however, the output is always a band, optimally symmetrical in shape. The width of the band at half its height is the instrumental bandwidth (IBW).

### Detectors

A detector converts a light signal into an electrical signal. Ideally, it should give a linear response over a wide range with low noise and high sensitivity. Spectrophotometers normally contain either a photomultiplier tube detector or a photodiode detector.

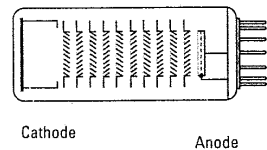
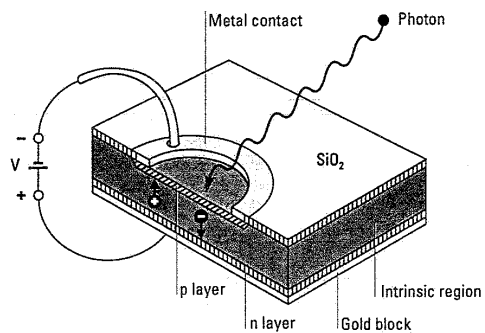

Figure 20  
The photomultiplier tube detector

The photomultiplier tube (see Figure 20) combines signal conversion with several stages of amplification within the body of the tube. The nature of the cathode material determines spectral sensitivity. A single photomultiplier yields good sensitivity over the entire UV-visible range. This type of detector yields high sensitivity at low light levels. However, in analytical spectroscopy applications, high sensitivity is associated with low concentrations, which result in low absorbances, which in turn result in high intensity levels. To detect accurately small differences between blank and sample measurements, the detector must have low noise at high intensity levels.

Increasingly, photodiodes are used as detectors in spectrophotometers (see Figure 21). Photodiode detectors have a wider dynamic range and, as solid-state devices, are more robust than photomultiplier tube detectors. In a photodiode, light falling on the semiconductor material allows electrons to flow through it, thereby depleting the

charge in a capacitor connected across the material. The amount of charge needed to recharge the capacitor at regular intervals is proportional to the intensity of the light. Earlier photodiodes had low sensitivity in the low UV range, but this problem has been corrected in modern detectors. The limits of detection are approximately 170–1100 nm for silicon-based detectors.



**Figure 21**  
The photodiode detector

Some modern spectrophotometers contain an array of photodiode detectors instead of a single detector. A diode array consists of a series of photodiode detectors positioned side by side on a silicon crystal. Each diode has a dedicated capacitor and is connected by a solid-state switch to a common output line. The switches are controlled by a shift register (see Figure 22). Initially, the capacitors are charged to a specific level. When photons penetrate the silicon, free electrical charge carriers are generated that discharge the capacitors. The capacitors are recharged at regular intervals that represent the measurement period for each scanning cycle.

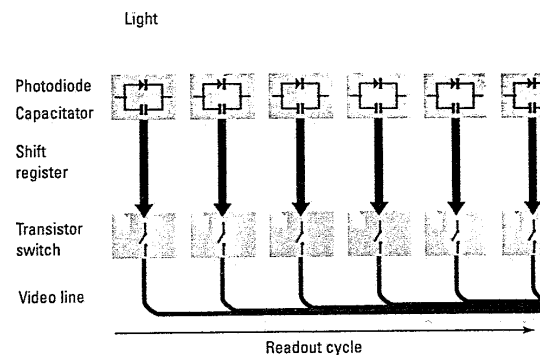

**Figure 22**  
Schematic diagram of a photodiode array

The amount of charge needed to recharge the capacitors is proportional to the number of photons detected by each diode, which in turn is proportional to the light intensity. The absorption spectrum is obtained by measuring the variation in light intensity over the entire wavelength range. The array typically comprises between 200 and 1000 elements, depending on the instrument and its intended application. For example, the diode array of the HP 8453 spectrophotometer comprises 1024 detector elements, and the photosensitive area measures approximately  $25 \times 0.5$  mm. The readout cycle, which corresponds to the illumination time, is 100 ms.

Photodiode array technology is similar to microprocessor technology. Photodiode arrays are complex devices but, because they are solid state, have high reliability.

**Optics** Either lenses or concave mirrors are used to relay and focus light through the instrument. Simple lenses are inexpensive but suffer from chromatic aberration, that is, light of different wavelengths is not focused at exactly the same

point in space. However, with careful design, the chromatic aberrations of individual lenses in an optical system can be used to cancel each other out, and an effective optical system can be constructed with these simple and inexpensive components.

Achromatic lenses combine multiple lenses of different glass with different refractive indices in a compound lens that is largely free of chromatic aberration. Such lenses are used in cameras. They offer good performance but at relatively high cost.

Concave mirrors are less expensive to manufacture than achromatic lenses and are completely free of chromatic aberration. However, the aluminum surface is easily corroded, resulting in a loss of efficiency.

At each optical surface, including the interfaces between components in an achromatic lens, 5–10 % of the light is lost through absorbance or reflection. Thus spectrophotometers ideally should be designed with a minimum number of optical surfaces.

### The conventional spectrophotometer

Figure 23 shows a schematic of a conventional single-beam spectrophotometer. Polychromatic light from the source is focused on the entrance slit of a monochromator, which selectively transmits a narrow band of light. This light then passes through the sample area to the detector. The absorbance of a sample is determined by measuring the intensity of light reaching the detector without the sample (the blank) and comparing it with the intensity of light reaching the detector after passing through the sample. As discussed above, most spectrophotometers contain two source lamps, a deuterium lamp and a tungsten lamp, and use either photomultiplier tubes or, more recently, photodiodes as detectors.

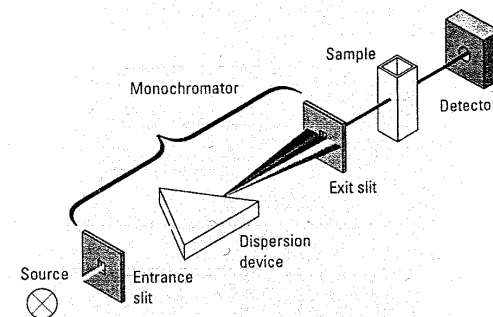

Figure 23  
Schematic of a conventional spectrophotometer

This design is well-suited for measuring absorbance at a single point in the spectrum. It is less appropriate, however, for measuring different compounds at different wavelengths or for obtaining spectra of samples. To perform such tasks with a conventional spectrophotometer, parts of the monochromator must be rotated, which introduces the problem of mechanical irreproducibility into the measurements. Moreover, serial data acquisition is an inherently slow process.

### The diode array spectrophotometer

Figure 24 shows a schematic diagram of a diode array spectrophotometer. Polychromatic light from a source is passed through the sample area and focused on the entrance slit of the polychromator. The polychromator disperses the light onto a diode array, on which each diode measures a narrow band of the spectrum. The bandwidth of light detected by a diode is related to the size of the polychromator entrance slit and to the size of the diode. Each diode in effect performs the same function as the exit slit of a monochromator.

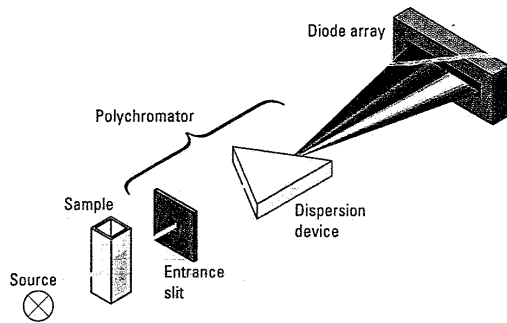

Figure 24  
Schematic of a diode array spectrophotometer

The polychromator (entrance slit plus dispersion device) and the diode array are contained in a unit known as a spectrograph. Because the relative positions of the sample and the dispersive element are reversed compared with a conventional instrument, this configuration often is referred to as reversed optics.

To minimize possible photochemical reactions, a shutter is used to block light from the source until a measurement can be performed. When the measurement is initiated, the shutter is automatically opened, and light passes through the sample to the array of diodes. The difference in the intensities of the light reaching the detector with and without the sample is measured as described in "The conventional spectrophotometer" on page 44. A diode array spectrophotometer is inherently very fast owing to its parallel data acquisition and electronic scanning capabilities, has excellent wavelength reproducibility, and is highly reliable.

**Configuration** Various configurations of spectrophotometers are commercially available. Each has its advantages and disadvantages.

**Single-beam design** Both conventional and diode array spectrophotometers are single beam. Single-beam instruments are low in cost, and the simple optical system offers high throughput and hence high sensitivity. The reference spectrophotometers used by national standards institutions such as the National Institute of Standards and Technology (NIST) in the United States and the National Physical Laboratory (NPL) in the United Kingdom are single beam.

Diode array spectrophotometers in particular are well-suited to single-beam configuration because spectra are acquired very quickly and because the time interval between blank and sample measurements is minimized. In addition, internal referencing can be used to reduce further the effects of lamp drift (see "Internal referencing" on page 80).

Figure 25 shows the optical system of a modern diode array spectrophotometer, the HP 8453. This single-beam configuration has a minimum number of optical components for highest throughput efficiency and contains a 1024-element diode array for measuring the wavelength range from 190 to 1100 nm with good resolution.



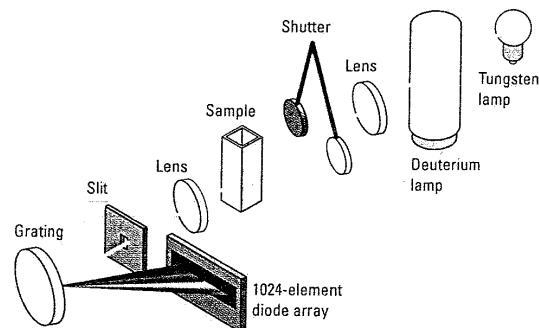

Figure 25  
Optical diagram of the HP 8453 diode array spectrophotometer

### Dual-beam design

In a conventional single-beam spectrophotometer, the blank and the sample are measured consecutively, with an interval of several seconds for a single wavelength measurement and up to several minutes for a full spectrum measurement with a conventional instrument. Lamp drift can result in significant errors over long time intervals.

The dual-beam spectrophotometer was developed to compensate for these changes in lamp intensity between measurements on blank and sample cuvettes. In this configuration, a chopper is placed in the optical path, near the light source. The chopper switches the light path between a reference optical path and a sample optical path to the detector. It rotates at a speed such that that the alternate measurements of blank and sample occur several times per second, thus correcting for medium- and long-term changes in lamp intensity (drift).

Figure 26 shows a schematic of a dual-beam spectrophotometer. Compared with single-beam designs, dual-beam instruments contain more optical components,

which reduces throughput and sensitivity. For high sensitivity, long measurement times may be required. In addition, the more complex mechanical design of the dual-beam spectrophotometer may result in poorer reliability.

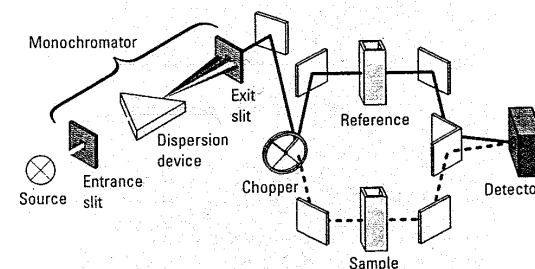

Figure 26  
Optical system of a dual-beam spectrophotometer

Traditionally, the higher stability of dual-beam instruments has been a major factor in the design of high-performance spectrophotometers. However, recent advances in lamp and electronics design have improved the stability of the single-beam spectrophotometer and led to the resurgence of this configuration. Single-beam instruments offer higher sensitivity and greater ease of use, with drift typically only a factor of two worse than that of dual-beam instruments.

The first commercially available diode array spectrophotometer, the HP 8450A, was a multibeam design (see Figure 27). The beam director is used to shift the beam alternately through the reference position and as many as four sample positions (for clarity only one is shown in the figure).

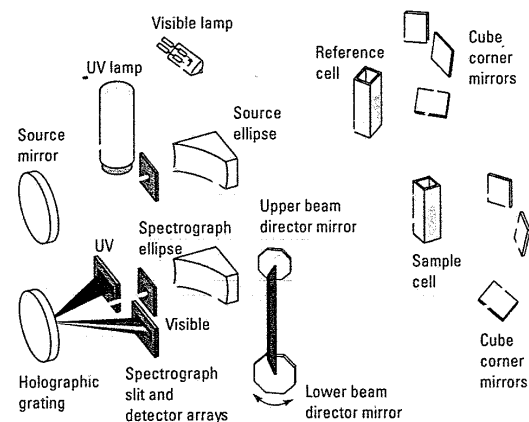

Figure 27  
Optical system of the HP 8450A diode array spectrophotometer

#### Split-beam design

The split-beam spectrophotometer (see Figure 28) resembles the dual-beam spectrophotometer but uses a beam splitter instead of a chopper to send light along the blank and sample paths simultaneously to two separate but identical detectors. This configuration enables the blank and the sample to be measured at the same time. Although the split-beam design is mechanically simpler than the true dual-beam instrument and requires fewer optical elements, the use of two independent detectors introduces another potential source of drift.

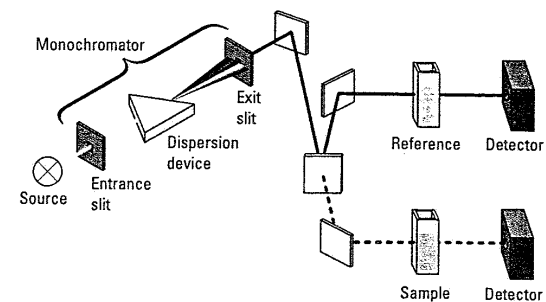

Figure 28  
Optical system of a split-beam spectrophotometer

This design provides high stability, although not as high as a dual-beam instrument since two detectors can drift independently, and good noise, although not as good as a single-beam instrument since the light is split so that less than 100 % passes through the sample.

#### Dual-wavelength design

With a dual-wavelength spectrophotometer, two wavelengths can be measured simultaneously for special applications, such as the study of two concurrent reactions in a sample. The monochromator contains two dispersion devices (in effect transforming it into a duochromator), with the output combined into a single beam. These complex instruments typically are significantly more expensive than conventional spectrophotometers and have been largely replaced by diode array spectrophotometers, which are multiwavelength instruments.

#### Measuring a spectrum

The degree of interaction of the sample with radiation (transmittance or absorbance) is determined by measuring both the intensity of the incident radiation (without the sample) and the transmitted intensity (with the sample).

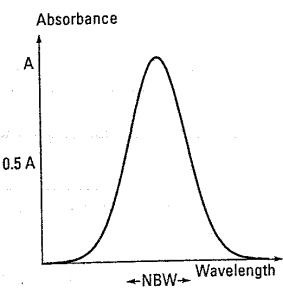

Figure 31  
Natural spectral bandwidth

The accuracy of any measured absorbance depends on the ratio of the SBW to the natural bandwidth (NBW) of the absorbing substance. The NBW is the width of the sample absorption band at half the absorption maximum (see Figure 31).

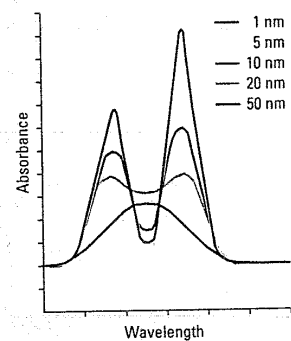

Figure 32  
Effect of varying SBW on measured band shape

An SBW/NBW ratio of 0.1 or less will yield an absorbance measurement with accuracy of 99.5% or better.<sup>8,9</sup> At an SBW/NBW ratio of higher than 0.1, the measured spectrum becomes progressively more distorted, as shown in Figure 32. Bands may not be resolved correctly, and significant errors in absorbance values will occur at most wavelengths. SBW is primarily a function of the entrance and exit slit widths of the monochromator, and of the dispersion generated by the grating. Resolutions of 0.5, 0.2, and 0.1 nm are not unusual, but higher resolutions cause considerable deterioration in S/N.<sup>10</sup>

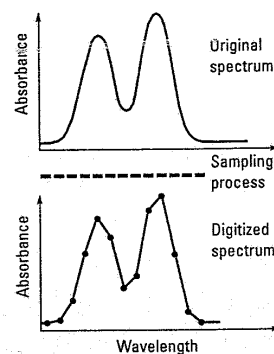

Figure 33  
Effect of digital sampling

In modern spectrophotometers, the sampling interval used to digitize the spectrum for computer evaluation and storage also affects resolution (in a diode array spectrophotometer, digitization occurs on the array itself). Figure 33 shows this effect. If the sampling interval is large relative to the SBW, the resolution of the instrument will be degraded. A smaller sampling interval improves resolution but results in much larger spectral files, which may be difficult to manage. In practice, the sampling interval is best set at equal to or slightly smaller than the SBW.

When considering instrumental requirements, it is important to determine what resolution is required. As discussed in Chapter 1 "Principles and applications of UV-visible spectroscopy", absorption bands in the UV-visible region are normally rather broad, particularly for samples in solution. For approximately 99% of routine measurements, an SBW of 2 nm is more than adequate to yield accurate absorbance measurements of bands with an NBW of 20 nm or greater.

If an instrument with an SBW of 2 nm is used to measure samples with an NBW narrower than 20 nm (for example, benzene), an error in absolute absorbance measurements will result. This error increases as the NBW decreases (see Figure 32). For absolute absorbance measurements, an instrument with a narrower SBW is necessary. However, most UV-visible measurements are used for quantification, which normally requires only relative measurements (for example, the absorbance of an unknown concentration relative to the absorbance of a standard). A calibration performed using standards, which bracket the concentration of the unknown sample, will yield accurate quantitative results even for very narrow bands.

### Wavelength accuracy and precision

The difference between wavelength accuracy and wavelength precision usually is not well understood (see Appendix A for an explanation of the difference between

These intensities are denoted  $I_0$  and  $I$ , respectively, in the equations in "Transmittance and absorbance" on page 14.

Because most samples measured with UV-visible spectroscopy are in solution, the blank should be measured on a cuvette containing the pure solvent used to prepare the sample. This process eliminates from the sample measurement any absorbance due to the solvent.

With a single-beam instrument, the cuvette containing the solvent is placed in the spectrophotometer, and the blank is measured. The sample solution is then measured in the same cuvette. All modern instruments automatically store the reference  $I_0$  values, which are used to calculate absorbance values for the sample.

With a dual- or split-beam instrument, two cuvettes are required. Both cuvettes are initially filled with pure solvent, and a so-called balance measurement is performed. This measurement reflects the difference in absorbance between the two optical paths in use. The sample cuvette is then filled with the sample solution for measurement, and  $I_0$  and  $I$  are measured virtually simultaneously. The resulting spectrum is corrected by subtracting the balance spectrum.

## Key instrumental parameters

### Spectral resolution

In this section we discuss some instrumental parameters that may affect the accuracy and precision of measured absorbance values (see Appendix A for a detailed definition of the terms accuracy and precision). Sources of error in measurements related to sample handling are described in Chapter 3 "Sample handling and measurement".

Spectral resolution is a measure of the ability of an instrument to differentiate between two adjacent wavelengths. Two wavelengths usually are considered resolved if the minimum between the two peaks of the detector output signal is lower than 80 % of the maximum. This condition is known as the Rayleigh criterion. Figure 29

shows schematically a case for two closely adjacent emission lines (the input to the instrument) and the actual signal that is output from the detector.

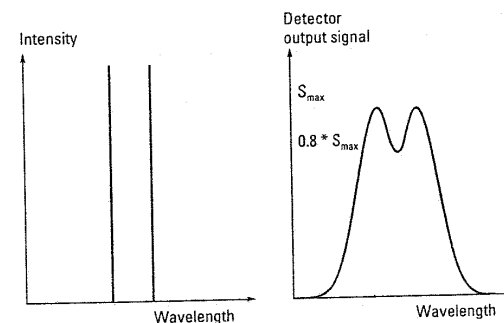

Figure 29  
Definition of resolution

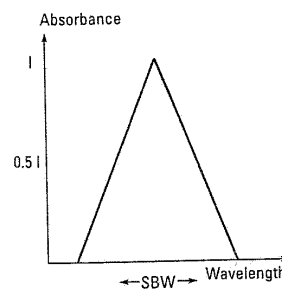

Figure 30  
Instrumental spectral bandwidth

Resolution is closely related to instrumental spectral bandwidth (SBW). The SBW is defined as the width, at half the maximum intensity, of the band of light leaving the monochromator (see Figure 30).

accuracy and precision). Wavelength accuracy is important for the comparison of measurements made on different instruments. In most UV-visible analyses, however, measurements are made on the same instrument relative to a standard, and wavelength precision (that is, resettability) is most important.

Figure 34 shows the effect of poor wavelength resettability. If a wavelength at the absorption maximum is selected for quantitative measurements, the small wavelength errors that occur in resetting the spectrophotometer to that wavelength will have a minimal effect on the measured absorbance. This method yields the most reproducible quantitative results. On the other hand, the choice of a wavelength on the side of the absorption band, with the same wavelength resetting error, will result in significant errors in measured absorbance. In this case, the quantitative results are unreliable.

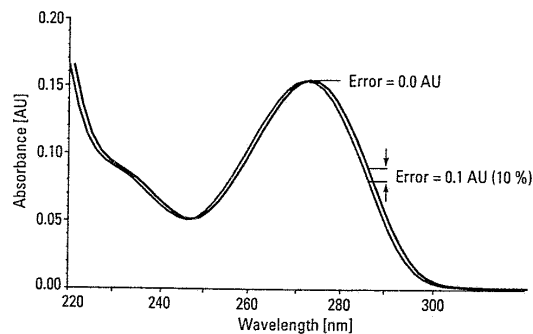

Figure 34  
Effect of poor wavelength resettability

All standard texts on UV-visible spectroscopy emphasize that, for accurate quantification, the analytical wavelength must be at the absorption maximum, even though other

wavelengths may yield better selectivity. However, these texts are based on conventional mechanical scanning techniques and do not apply to diode array instruments, which have virtually absolute wavelength resettability.

### Photometric accuracy and precision

Assuming good optical and electronic design, only two factors influence photometric accuracy and precision: stray light and noise.

**Stray light** Stray light is defined as detected light of any wavelength that lies outside the bandwidth of the selected wavelength. The equation used to calculate transmittance and thereby absorbance is:

$$T = (I + I_s) / (I_0 + I_s)$$

where  $T$  is transmittance,  $I_0$  is the intensity of incident light,  $I$  is the intensity of transmitted light, and  $I_s$  is the intensity of stray light.

The intensity of stray light normally does not depend on that of transmitted light. If  $I_s$  remains near constant, it becomes the dominant term at low levels of  $I$ . At high absorption, stray light causes a negative bias in instrument response and eventually is the limiting factor for the absorbance, and thereby concentration, that can be measured. The photometric accuracy of the instrument is thus compromised. Figure 35 shows the effect of various levels of stray light on measured absorbance compared with actual absorbance.

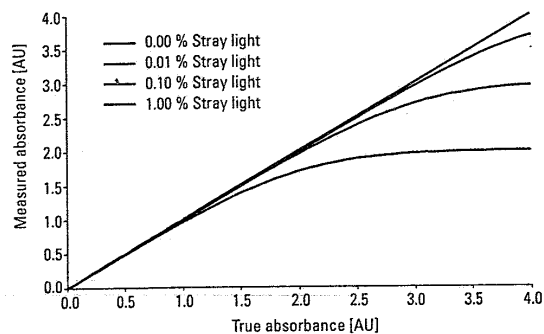

Figure 35  
Effect of stray light on measured sample absorbance

**Noise** A spectrophotometer typically has two noise elements. The first element (photon or Schott noise) results from the statistical distribution of the photons emitted by a light source. It is proportional to the square root of the intensity of light. When low concentration samples with low absorbances are measured, this element may prevent an accurate measurement of the small difference between two high light levels. The second element is inherent to the instrument electronics (detector amplifier, analog-to-digital converter, and so forth) and is independent of the intensity measured. This element becomes significant at high absorbance levels, where the sample signal is very small. It can be minimized through good design.

Noise negatively affects the precision of measurements and, for any single measurement, may introduce errors in accuracy as well. However, noise can be reduced by increasing measurement time (see "Time averaging" on page 73).

**Linear dynamic range** A frequently quoted and often misunderstood specification is instrument range. In most cases, the instrument range is simply the numerical range an instrument can display. A more useful specification is linear dynamic range, which specifies for a given acceptable deviation from linearity (as a percentage of absorbance) the minimum and maximum absorbance values.

Potential errors at different absorbances can be calculated from stray light and noise.

Thus, error due to stray light (%) is equal to

$$(A_t - A_m) / (A_t \times 100)$$

where  $A_t = -\log(I/I_0)$

$$\begin{aligned} \text{and } A_m &= -\log[(I + I_s)/(I_0 + I_s)] \\ &= \log[(I + I_s/I_0)/(I/I_0 + I_s/I_0)] \end{aligned}$$

where  $I_0$  is incident light intensity,  $I$  is transmitted light intensity,  $I_s$  is stray light intensity,  $I_t$  is stray light as a percentage of  $I_0$ ,  $A_t$  is true absorbance, and  $A_m$  is measured absorbance. Figure 35 shows the error curve due only to stray light.

In addition, the measured absorbance may be in error because of the instrument noise.

Thus, error due to noise (%) is equal to

$$(A_t - A_m) / (A_t \times 100)$$

where  $A_t = -\log(I/I_0)$

$$\text{and } A_m = A_t + \sqrt{T}/100 \times A_{pn} + A_{en}$$

$$\text{or } A_m = \sqrt{T}/100 \times A_{pn} + A_{en}$$

where  $A_{pn}$  is photon noise in AU,  $A_{en}$  is electronic noise in AU, and  $T$  is transmittance as a percentage.

The total error at any absorbance is the sum of the errors due to stray light and noise. Figure 36 depicts the total error for an example with photon noise of  $\pm 0.0004$  AU and electron noise of  $\pm 0.0001$  AU. The plot shows that absorbance measurements made from approximately 0.3 to 1.0 AU have the highest accuracy and precision. The instrumental dynamic range can be determined from the acceptable measurement error.

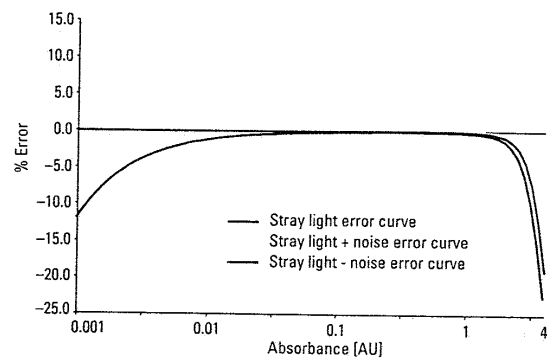

Figure 36  
Theoretical absorbance error versus absorbance

**Drift** Another potential cause of photometric error is drift. Drift normally results from variations in lamp intensity between the measurement of  $I_0$  and the measurement of  $I$ . Changes in the instrument electronics also can cause drift. Good instrumental design can minimize drift, but this effect can reduce the accuracy of results, especially over a long period of time (see Figure 37). With multiwavelength data, the problem of drift can be minimized using techniques such as internal referencing (see "Internal referencing" on page 80).

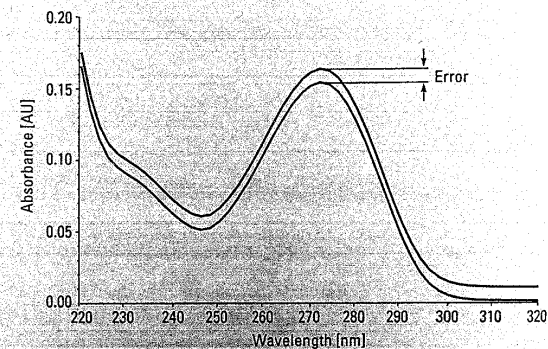

Figure 37  
Effect of drift on measured absorbance values